

SNP-312/412 SLICER

Grote's SNP-312 or 412 Slicer is intended for single-lane targeting applications. It slices and applies product directly onto moving targets such as a bun, tray, or conveyor belt. The SNP-312 is ideally suited for high-volume bacon slicing systems to produce exact weight portions. If a portion is light in weight, the SNP-312 adds a single slice of bacon to the portion to meet the target weight. This allows the primary slicer to be set to tighter tolerances for less product give away.

Production rates are adjustable up to 120 strokes per minute. Product logs may be continually loaded into the product holder while the machine is in operation.

With its cantilevered design, the SNP-312/412 sets directly over your production line. Operators may easily adjust slicing head height, and reverse the frame for right or left-hand operation.

A user-friendly keypad, with easily identifiable symbols, controls most functions. Instantly adjust slicing speed, slicing mode, and blade lubrication with the touch of a finger.

Easy, no-tool access to areas requiring sanitation allows thorough cleaning.



GROTE

Count on Grote for *all* your slicing needs!



Adds a single slice of bacon to make weight for exact weight retail packages.

AccuBand

The SNP-312 utilizes Grote's patented AccuBand® cutting system for optimal slice quality and product yield. AccuBand cuts with a 1/2" wide razor-sharp band blade running continuously between two pulleys. The blade cleanly and consistently cuts through entire product logs, including butt ends, to produce the highest yield of usable slices. Most boneless/non-frozen products may be sliced. These disposable blades eliminate the need for resharpening and simplify the cleanup process.

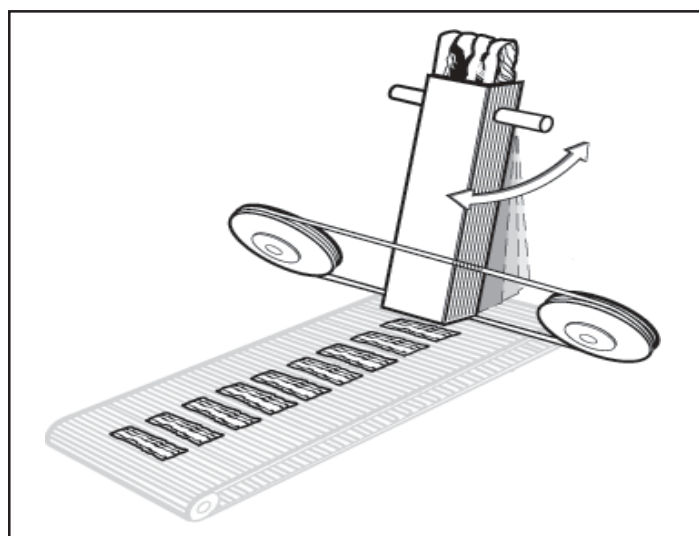

Dimensional Drawings

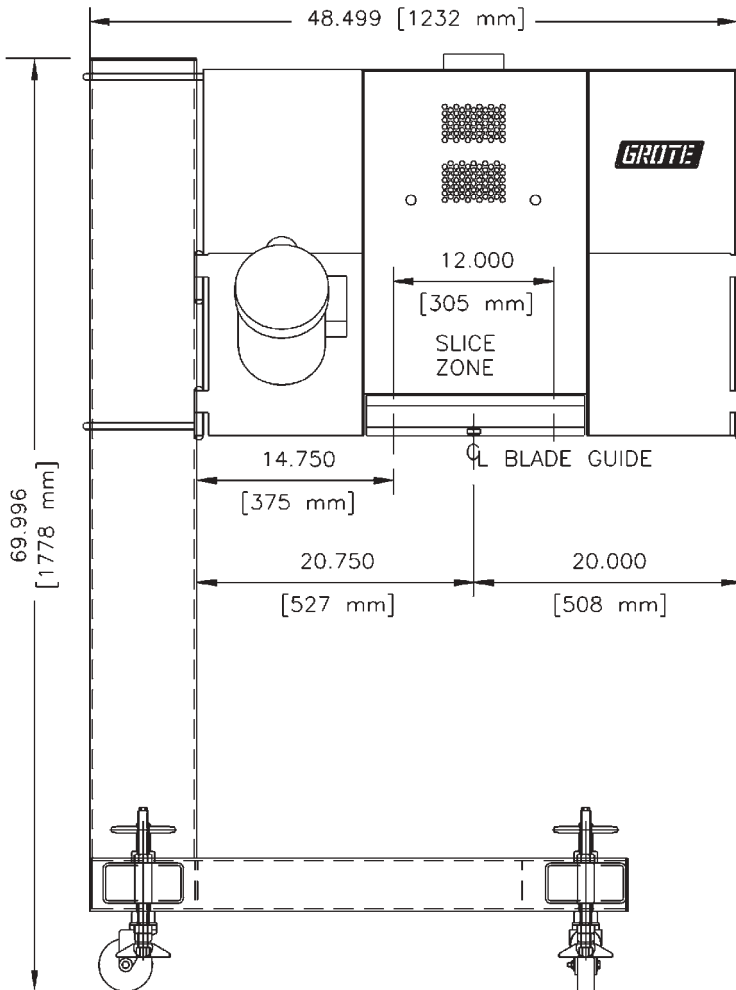

FRONT VIEW

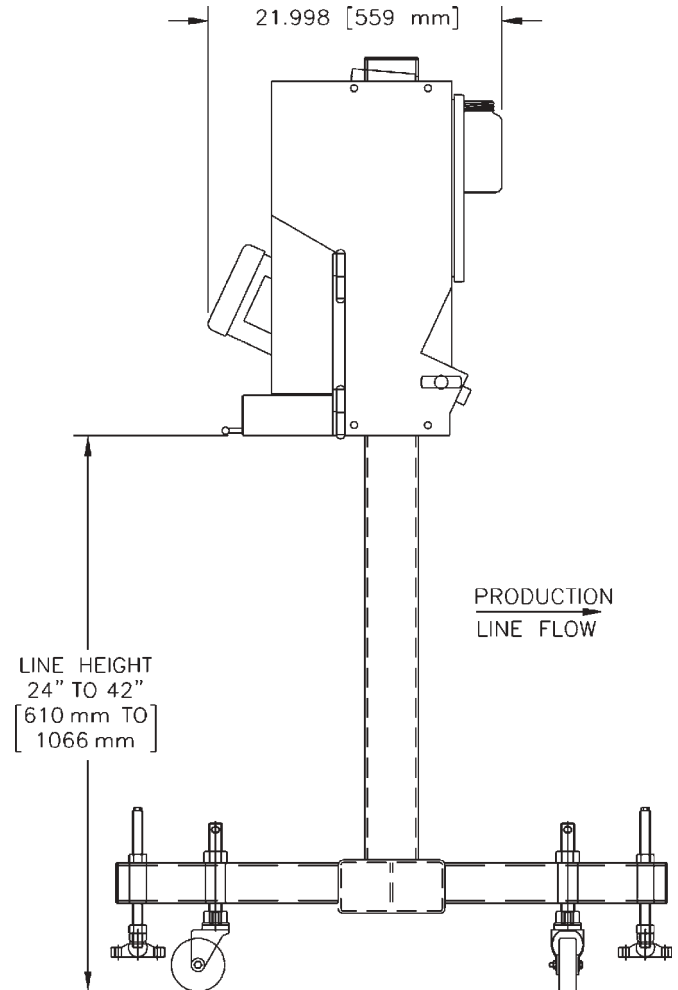

SIDE VIEW

Features

- Adjustable speed up to 120 strokes per minute.
- Accepts signal from all major scale manufacturers.
- All electric drive.
- 3" or 4" x 12" (76mm x 305mm) cutting area.
- Variable slice thickness up to 3/8".
- 26" tall product holder.
- Target and bulk slice modes.
- Cantilevered frame with pedestal base.
- Stainless steel construction.
- Adjustable deposit height.
- Blade motor: 1 H.P.
- Emergency stop button.
- Casters.
- Electrical: 230 VAC, 1 Phase, 50/60 Hz.
- Utilizes AccuBand® cutting system.
- Continuous product loading during operation.
- Gravity feed.

Corporate Office

1160 Gahanna Parkway
Columbus, OH 43230
United States of America
Tel.: 614-868-8414
Fax: 614-863-1647

E-mail: sales@grotecompany.com



Precision slicing & application systems

www.grotecompany.com

European Sales & Service

Wrexham Technology Park
Wrexham, North Wales LL137YP
United Kingdom
Tel.: 44 (0) 1978-362243
Fax: 44 (0) 1978-362255

E-mail: sales@intl.grotecompany.com