

613-VS2 MULTI-SLICER



Model 613-VS2

Bulk slices, stacks, and shingles into portions at rates from 37 up to 90 strokes per minute, per lane.

AccuBand®

The 613-VS2 Multi-Slicer utilizes Grote's patented AccuBand® cutting system for optimal slice quality and product yield. AccuBand cuts with a 1/2" wide razor-sharp band blade running continuously between two pulleys. The blade cleanly and consistently cuts through the entire product log, including butt ends, to produce the highest yield of usable slices. These disposable blades eliminate resharpening and simplify the cleanup process.

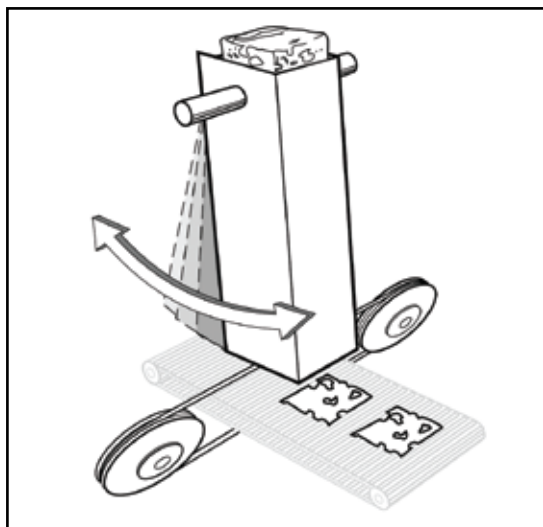

Count on Grote for *all* your slicing needs!

Grote's 613-VS2 Multi-Slicer is ideal for today's food service industry. It performs a variety of slicing applications, including bulk slicing, stacking, and shingling into portions.

Boneless/non-frozen meats, cheeses, vegetables, fruits, and bread products are all precisely sliced at a rate from 37 up to 90 strokes per minute, per lane. Product may be continuously loaded into the product holders while the machine is in operation.

Operation and sanitation are simple. The user-friendly keypad utilizes easily identifiable symbols to allow for quick and easy selection of slicer functions. Sloped surfaces and easily removable parts allow for thorough cleaning of all product residue.

The 613-VS2 Multi-Slicer is the perfect way to automate your processing operation. Its exceptional slice quality, ease of use, and portion consistency have made it a staple in the food service industry.

Dimensional Drawings

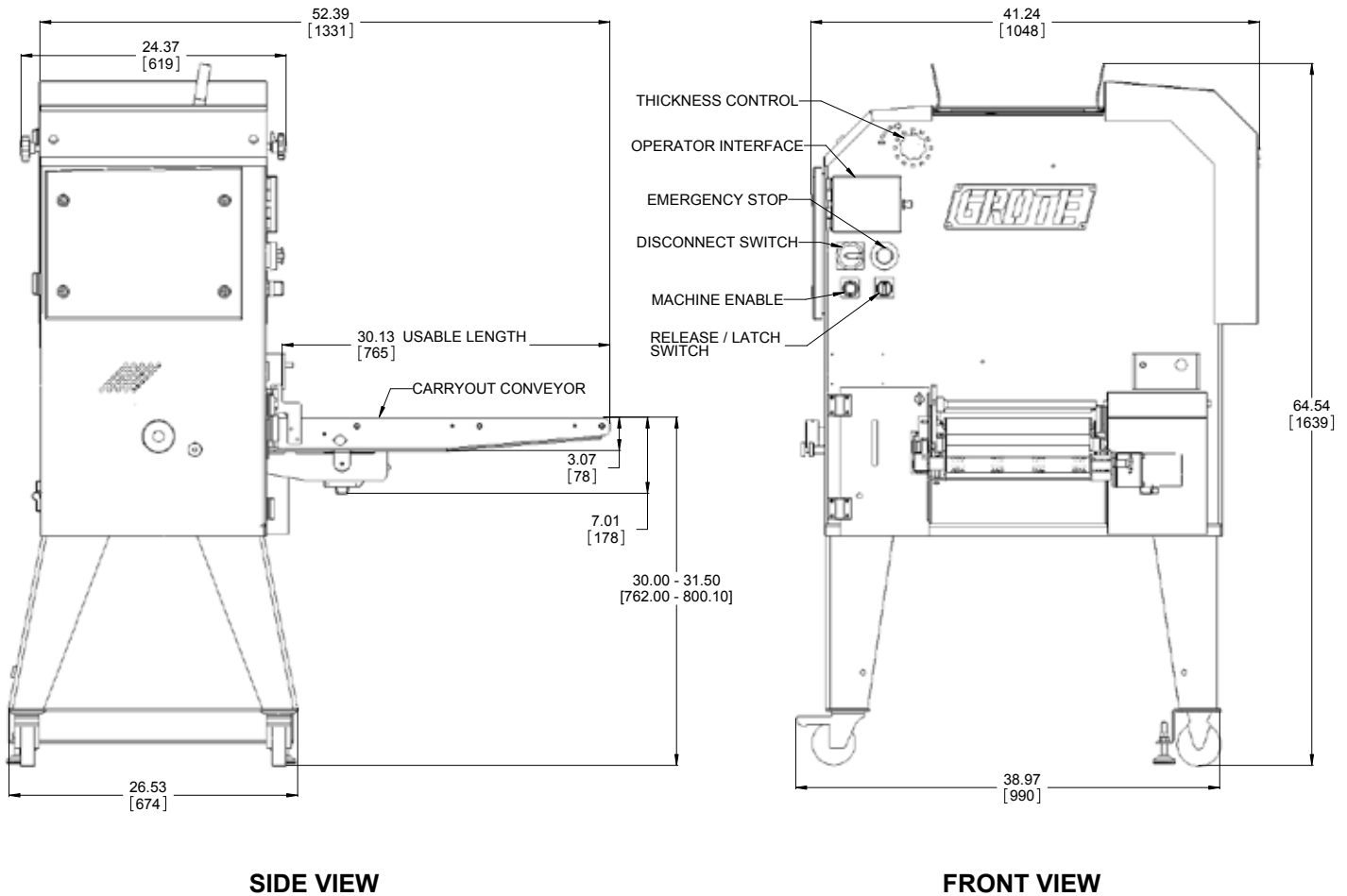

SIDE VIEW

FRONT VIEW

8/09

Features

- From 37 up to 90 strokes per minute, per lane.
- Bulk slice, stack, and shingle modes.
- 6" x 13" (152 x 330mm) slicing zone.
- 26" (660mm) tall product holder.
- Up to 2" (51mm) stack height.
- Variable slice thickness of .02" to .50" (.5mm to 12.7mm). Slicing greater than 1" thick option available on request.
- Slice counter for grouping slices.
- Variable group spacing.
- Shuttle conveyor for product stacking or shingling.
- Carryout conveyor (extended length available).
- Variable speed conveyor.
- Electrical: 200-240 VAC, 50/60 Hz, 1 Phase.
- Utilizes AccuBand® cutting system.
- Continuous product loading during operation.
- Gravity feed product method.
- Metric Fasteners.

Corporate Office

1160 Gahanna Parkway
Columbus, OH 43230
United States of America
Tel.: 614-868-8414
Fax: 614-863-1647

E-mail: sales@grotecompany.com



Precision slicing & application systems

www.grotecompany.com

European Sales & Service

Wrexham Technology Park
Wrexham, North Wales LL137YP
United Kingdom

Tel.: 44 (0) 1978-362243
Fax: 44 (0) 1978-362255

E-mail: sales@intl.grotecompany.com