

# FPS-1000 SLICER



*Bulk slices fresh produce at rates up to 120 strokes per minute, per lane.*

## AccuBand

The FPS-1000 utilizes Grote's patented AccuBand® cutting system for optimal slice quality and product yield. AccuBand cuts with a 1/2" wide razor-sharp band blade running continuously between two pulleys. The blade cleanly and consistently cuts through the entire product to produce the highest yield of usable slices. Most fruits and vegetables can be sliced. These disposable blades eliminate the need for sharpening and simplify the cleanup process.

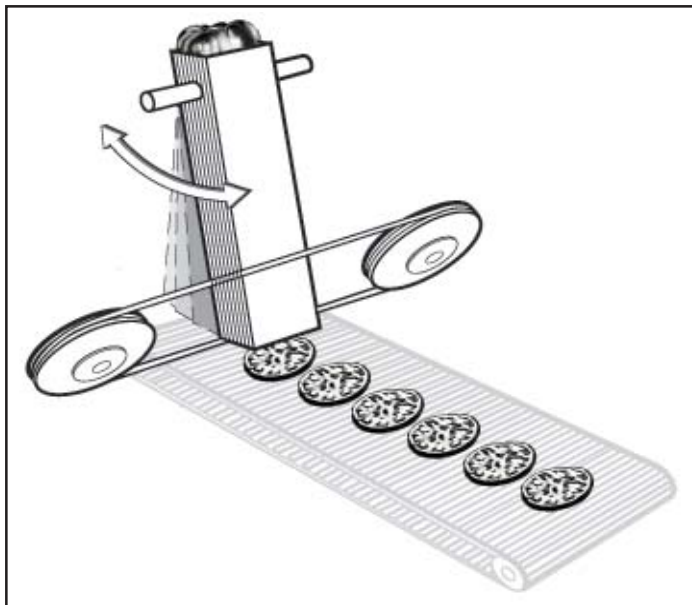

Whether you're slicing delicate tomatoes or rigid onions, Grote's new FPS-1000 Slicer is the ideal unit for your fresh-cut produce operation. A band blade slices produce cleanly and evenly for optimal results. It features a 30" wide slicing zone and an easy to clean, sanitary design.

This machine bulk slices at rates up to 120 strokes per minute, per lane. Produce may be continuously loaded into the product holders while the machine is in operation to enhance production output.

Operation of the FPS-1000 is simple. Since this slicer operates in bulk slice mode only, it utilizes basic controls for ease of operation. Functions such as slice thickness and slicing speed are adjusted in an instant with the turn of a knob during operation.

The FPS-1000 is the perfect way to automate your slicing operation. It was designed specifically for the fresh-cut industry, incorporating the needs of today's leading processors.



**Count on Grote for *all* your slicing needs!**

## Dimensional Drawings

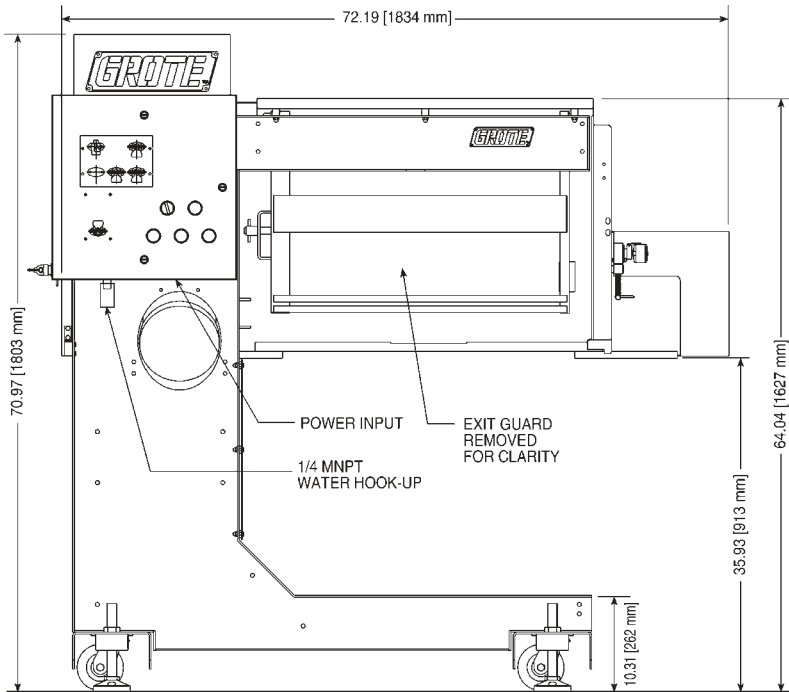

FRONT VIEW

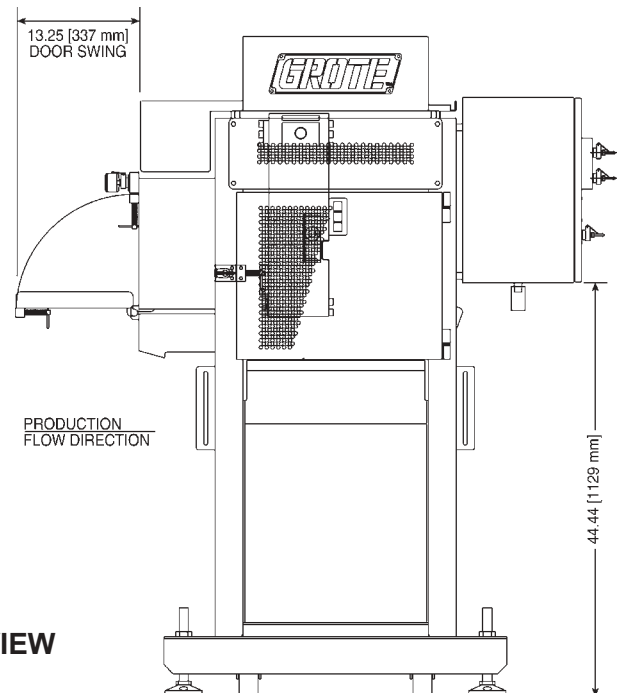

SIDE VIEW

## Features

- Adjustable speed up to 120 strokes per minute, per lane.
- Bulk slice mode.
- 30" cutting zone; 3.5" and 5" product stroke.
- Line height of 35".
- Slice thickness adjustable up to 1 1/2".
- Easy to operate and maintain.
- Auto water blade lubrication system.
- Electric drive.
- Electrical: 230 V 1Ø 50/60 Hz.
- Utilizes AccuBand® band blade cutting system.
- Continuous product loading during operation.
- Gravity feed.

### Corporate Office

1160 Gahanna Parkway  
Columbus, OH 43230  
United States of America  
Tel.: 614-868-8414  
Fax: 614-863-1647

E-mail: sales@grotecompany.com



Precision slicing & application systems

www.grotecompany.com

### European Sales & Service

Wrexham Technology Park  
Wrexham, North Wales LL137YP  
United Kingdom  
Tel.: 44 (0) 1978-362243  
Fax: 44 (0) 1978-362255

E-mail: sales@intl.grotecompany.com