

HORIZONTAL BREAD CUTTER

Grote's Horizontal Bread Cutter is a dual lane, stainless steel unit designed to horizontally cut virtually all types of fresh sandwich breads and rolls, including croissants, breakfast biscuits, bagels, sub buns and panini. The unit is ideal for in-line cutting of fresh breads & rolls and transferring them to a sandwich assembly conveyor for ingredient and topping placement. Cut height is fully adjustable between 1/2" and 1 1/2", and height adjustment is easily accomplished with the turn of a simple mechanical hand wheel. In addition to a 12" wide product transfer belt, the Horizontal Bread Cutter includes an independently driven upper feed belt to maintain positive pressure on each bread top during the cutting process. Hold down pressure on the upper belt can be varied to accommodate a wide range of bread products.

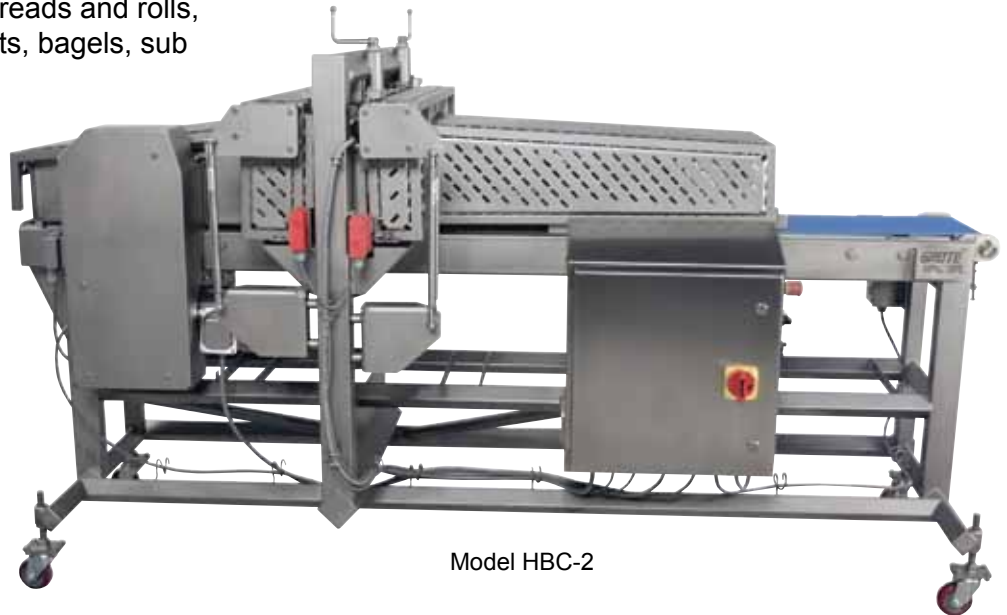

Model HBC-2

Ideal for in-line cutting of a wide variety of fresh sandwich breads and rolls.



AccuBand®

Cutting is accomplished using Grote's patented Accuband® band blade system for optimal cutting efficiency. Accuband cuts with a 1/2" wide razor sharp band blade running continuously between two pulleys. These disposable blades eliminate the need for sharpening and simplify the cleanup process. The Horizontal Bread Cutter is completely portable and guarding is hinged to allow easy access for cleaning, maintenance, and blade change. Options include an independent outfeed belt for creating gaps between sliced breads after they are discharged, as well as customized tooling to knock bread tops either behind or to the side of each bread bottom.

Count on Grote for all your slicing needs!



Dimensional Drawings

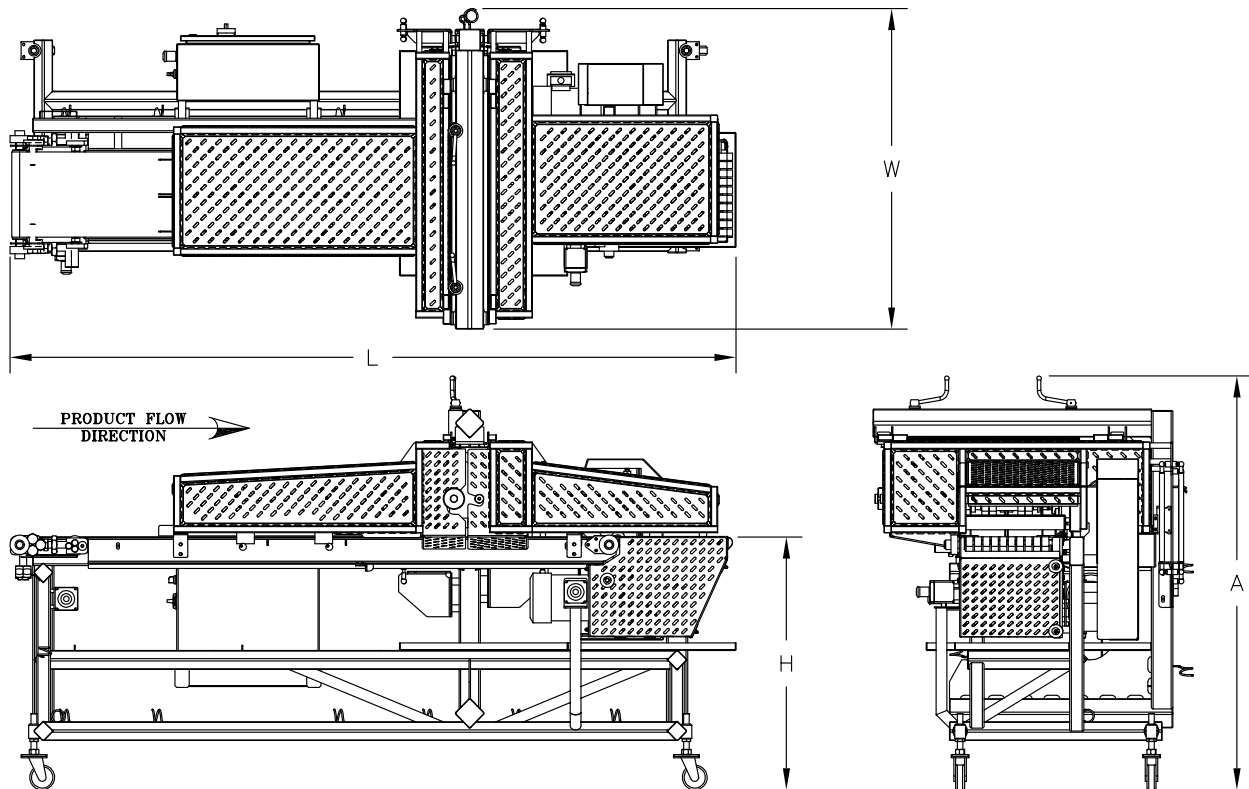

L	W	A	H	B
OVERALL LENGTH	OVERALL WIDTH	OVERALL HEIGHT	TOP OF BELT	BELT WIDTH
101.25"	43.63"	57.75"	35.5" ± 1"	12"
2572 mm	1108 mm	1467 mm	902 mm	305 mm

Features

- 12" feed belt
- 2 lane input/2 lane output standard
- Adjustable cut height from ½" to 1 ½"
- Capable of cutting product heights of up to 3.25"
- 40 FPM nominal transfer belt speed (with VFD adjustment for 13-80 FPM range)
- Electrical: 200 to 575 VAC/ 3 phase/ 50/60 Hz
- Pneumatic: None
- Washdown - IP 65 electrical rating
- Enhanced safety guarding
- Stainless steel construction

Corporate Office
 1160 Gahanna Parkway
 Columbus, OH 43230, USA
 US Tel: 614-868-8414
 US Toll Free: 888-534-7683
 US Fax: 614-863-1647
 e-mail: sales@grotecompany.com



European Sales & Service
 Wrexham Technology Park
 Wrexham, LL137YP, UK
 Tel: +44 (0) 1978-362243
 Fax: +44 (0) 1978-362255
 e-mail: sales@intl.grotecompany.com