

LSS-2 LINEAR STEAK & POULTRY SPLITTER

Grote's *new* LSS-2 Linear Steak & Poultry Splitter is ideal for splitting fresh poultry, pork, and beef. Incorporating Grote's Accuband band-blade cutting technology, the LSS-2 can cut whole muscle products lengthwise and effectively split them into two pieces.

The LSS-2 can split product of virtually any length and up to 3.0" in nominal height. Both single and dual infeed conveyor systems are available, with cutting zones of up to 10" per lane. The LSS-2 is designed of stainless steel construction, is easy to clean, and incorporates enhanced safety guarding for safe operation.

Product Slitter
Model LSS-2



Ideal Applications:

- Skirt steaks
- Poultry breasts
- Whole muscle size reduction and trimming

AccuBand

The Linear Steak Poultry Splitter utilizes Grote's patented Accuband® cutting system for optimal cutting efficiency. Accuband® cuts with a 1/2" wide razor-sharp band blade running continuously between two pulleys, and cleanly cuts through the entire length of the product being split. These disposable blades eliminate the need for resharpening and simplify the cleanup process.

Easy access
for easy
sanitation!

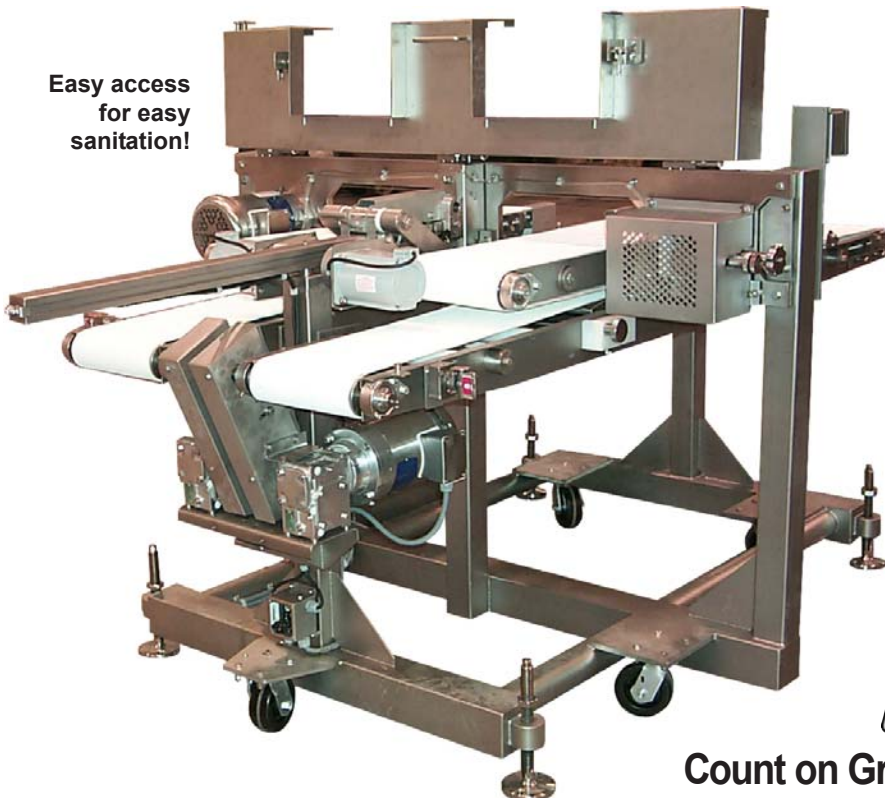

The logo for Grote, featuring the word "GROTE" in a bold, stylized font with a registered trademark symbol.

Count on Grote for *all* your slicing needs!

Dimensional Drawings

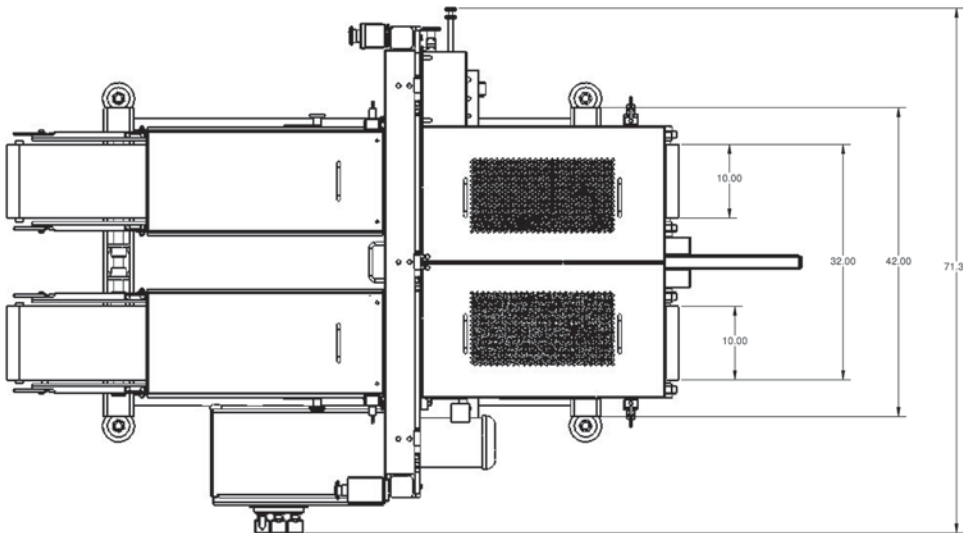

TOP VIEW

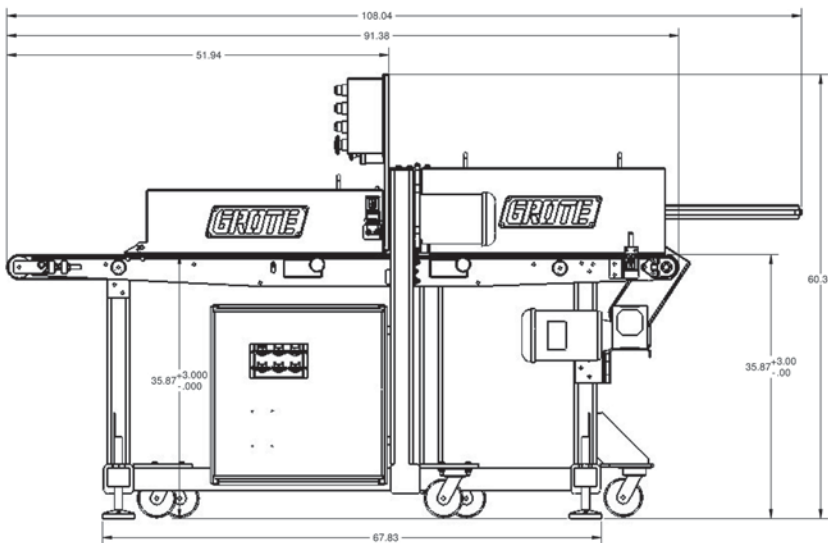

SIDE VIEW

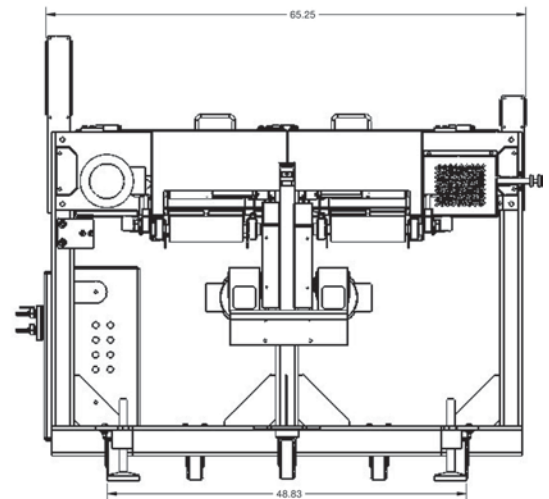

FRONT VIEW

Features

- Accepts products of virtually any length and up to 3.0" in nominal height
- Utilizes Grote Accuband® band blade cutting technology
- Adjustable thickness controls
- Up to 10" wide cut zone, per lane
- Stainless steel construction
- Electrical: 200 to 575 VAC, 3 phase, 50/60 Hz
- Single or dual infeed conveyors
- Positive feed upper and lower conveyors
- Enhanced safety guarding

Corporate Office

1160 Gahanna Parkway
Columbus, OH 43230
United States of America
Tel.: 614-868-8414
Fax: 614-863-1647

E-mail: sales@grotecompany.com



Precision slicing & application systems

www.grotecompany.com

European Sales & Service

Wrexham Technology Park
Wrexham, North Wales LL137YP
United Kingdom

Tel.: 44 (0) 1978-362243
Fax: 44 (0) 1978-362255

E-mail: sales@intl.grotecompany.com