

# SANDWICH ALIGNER/CUTTER AC-40

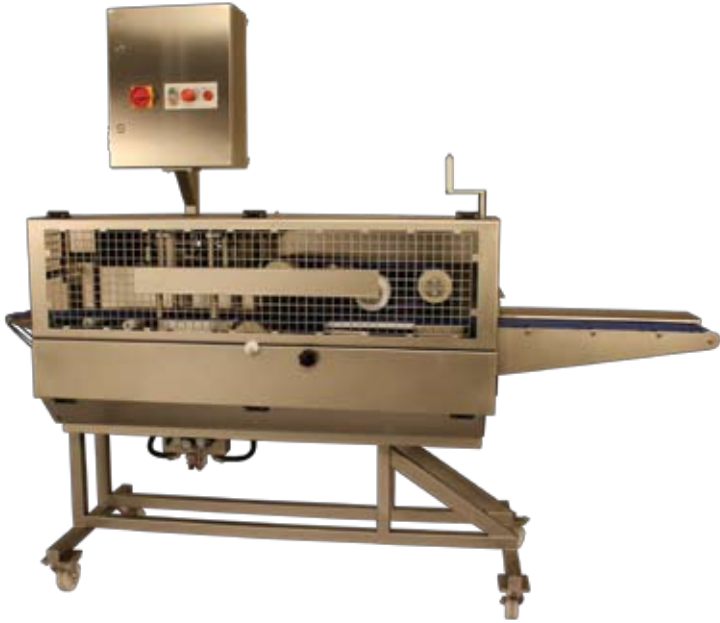

Grote's Sandwich Aligner/Cutter AC-40 is designed to center cut single or multiple sandwiches, corner to corner, into two halves. Utilizing a mechanical reciprocating blade as the cutting knife, it is capable of cutting up to 40 products per minute. The infeed section is designed for either direct in-line transfer from a sandwich assembly line or for hand placement of the sandwich from off-line locations. A photosensor automatically detects each pre-turned sandwich and initiates the alignment process. Once positioned within the alignment chamber, each sandwich/sandwich stack is mechanically aligned (top to bottom and front to back). The sandwich then passes through the reciprocating blade which cleanly cuts the center of each sandwich. The cutting blade motion ensures a minimum of sandwich filling spread, even with wet salads, and clean-up between production runs of different products is simple.

The AC-40 design includes a unique floating head system that maintains positive control of the sandwich during the entire cutting process. The floating head system utilizes upper control belts that compensate for minor product height differences by automatically adjusting the top pressure applied to each sandwich stack passing through the cutting chamber. The floating head system can also be pre-adjusted with a simple mechanical handwheel to allow for easy raising and lowering of the upper control belts when switching between different product stack heights (1, 2, or 3 sandwiches). No tools are required for removing belts and rollers and the blade is easily removed with a standard wrench. The small footprint of the AC-40 makes it easily portable and the front guard is hinged to allow easy access for cleaning and maintenance.

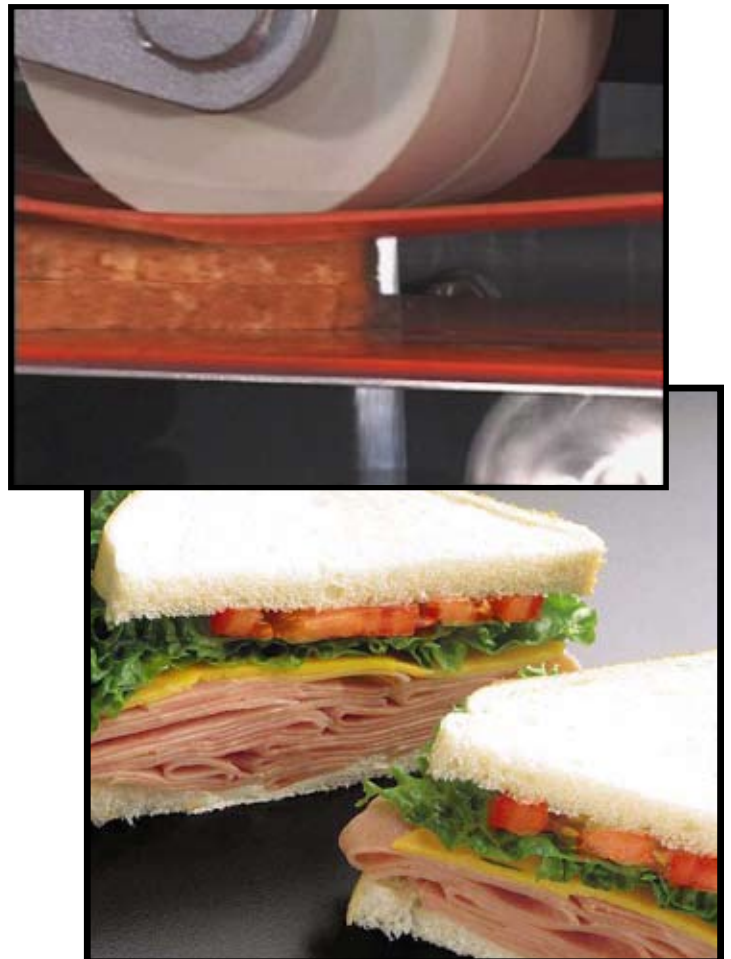

## Dimensional Drawings

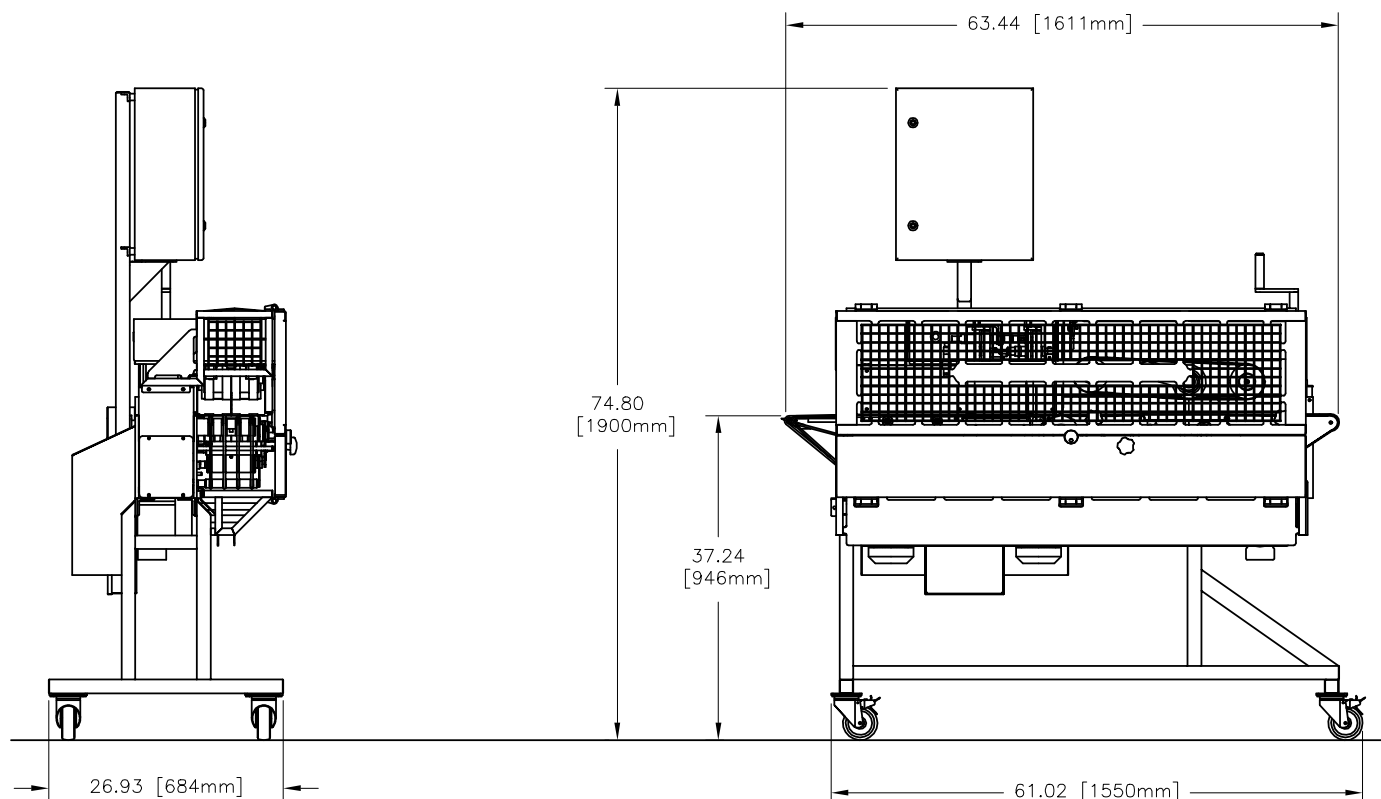

### Machine Overall Dimensions

Length	Width	Height
2200mm	700mm	1860mm

### Product Dimensional Limitations

Product Dimension	Minimum	Maximum
Length	90mm	130mm
Width	90mm	130mm
Height	20mm	75mm

### Features

- 40 cuts per minute on single stacks – *consult factory for cutting speeds on double and triple stacks.*
- Capable of cutting product heights of up to 5".
- Fully interlocking safety guard switches.
- Washdown - IP 65 electrical rating.
- Electrical: 200-575 VAC, 3 phase, 50/60 Hz.
- Air Requirements: 60psi.
- Simple belt release for easy cleaning of food contact areas.
- Right and left hand configurations available.
- Mitsubishi PLC and operator interface standard (*Allen-Bradley available upon request.*)

10/08

**Corporate Office**  
 1160 Gahanna Parkway  
 Columbus, OH 43230  
 United States of America  
 Tel.: 614-868-8414  
 Fax: 614-863-1647

E-mail: sales@grotecompany.com



*Precision slicing & application systems*

[www.grotecompany.com](http://www.grotecompany.com)

**European Sales & Service**  
 Wrexham Technology Park  
 Wrexham, North Wales LL137YP  
 United Kingdom

Tel.: 44 (0) 1978-362243  
 Fax: 44 (0) 1978-362255

E-mail: sales@intl.grotecompany.com