

# 713-SS MULTI-SLICER



Model 713-SS

*Bulk slices, stacks, and shingles into portions at a rate of 60 strokes per minute, per lane.*

## AccuBand

The 713-SS Multi-Slicer utilizes Grote's patented AccuBand® cutting system for optimal slice quality and product yield. AccuBand cuts with a 1/2" wide razor-sharp band blade running continuously between two pulleys. The blade cleanly and consistently cuts through the entire product log, including butt ends, to produce the highest yield of usable slices. These disposable blades eliminate resharpening and simplify the cleanup process.

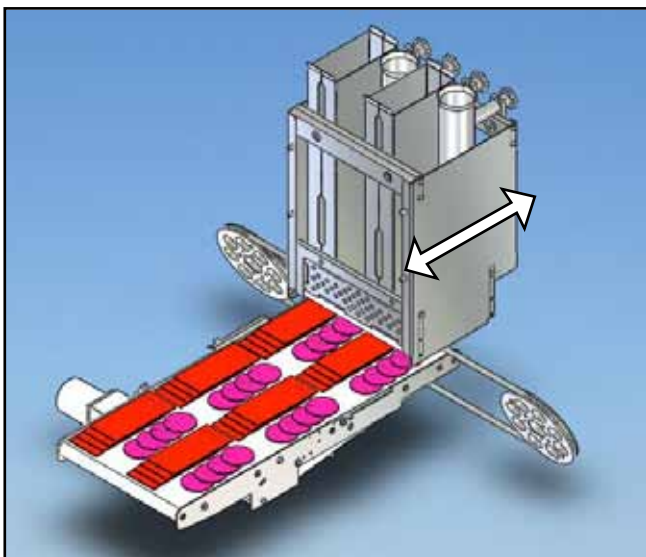

Grote's 713 Multi-Slicer has been a staple in the food service industry for over 20 years. The Grote 713-SS combines the same great versatility found in the 713 Multi-Slicer with several significant enhancements over previous models, including off-the-shelf electrical controls and an improved sanitary design. The new sanitary design includes sloped surfaces, substantially stainless steel construction, and a sealed cabinet for superior washdown protection of the clutch unit.

The 713-SS can perform a variety of slicing applications, including bulk slicing, stacking, and shingling into portions. In addition, its linear stroke action makes the 713-SS perfect for specialty slicing applications, such as bias cutting, and its 7" x 13" cut zone is ideal for slicing large whole muscle meat products. Boneless/non-frozen meats, cheeses, vegetables, fruits, and bread products are all precisely sliced at a rate of 60 strokes per minute per lane. Operation and sanitation are simple. The user friendly keypad utilizes easily identifiable symbols to allow for quick and easy selection of slicer functions. Product may be continuously loaded into the product holders and slice thickness can be easily adjusted while the machine is in operation.



Count on Grote for *all* your slicing needs!

## Dimensional Drawings

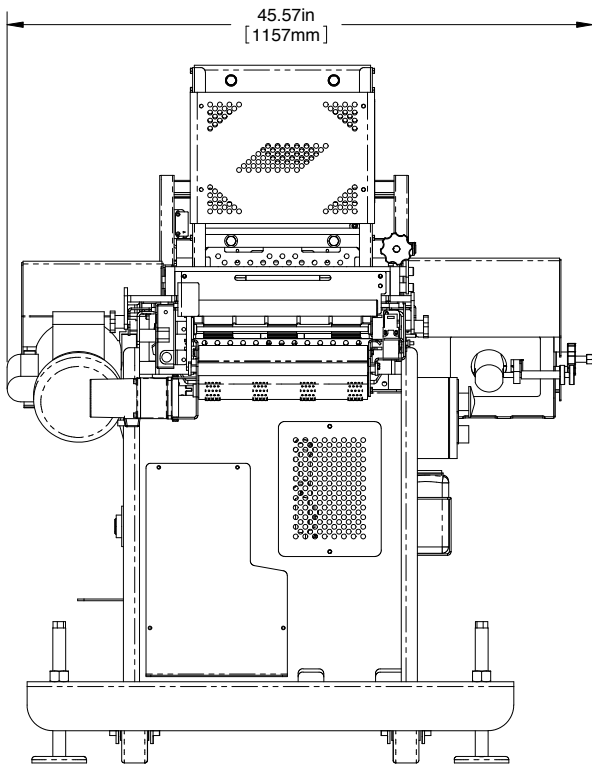

**FRONT VIEW**

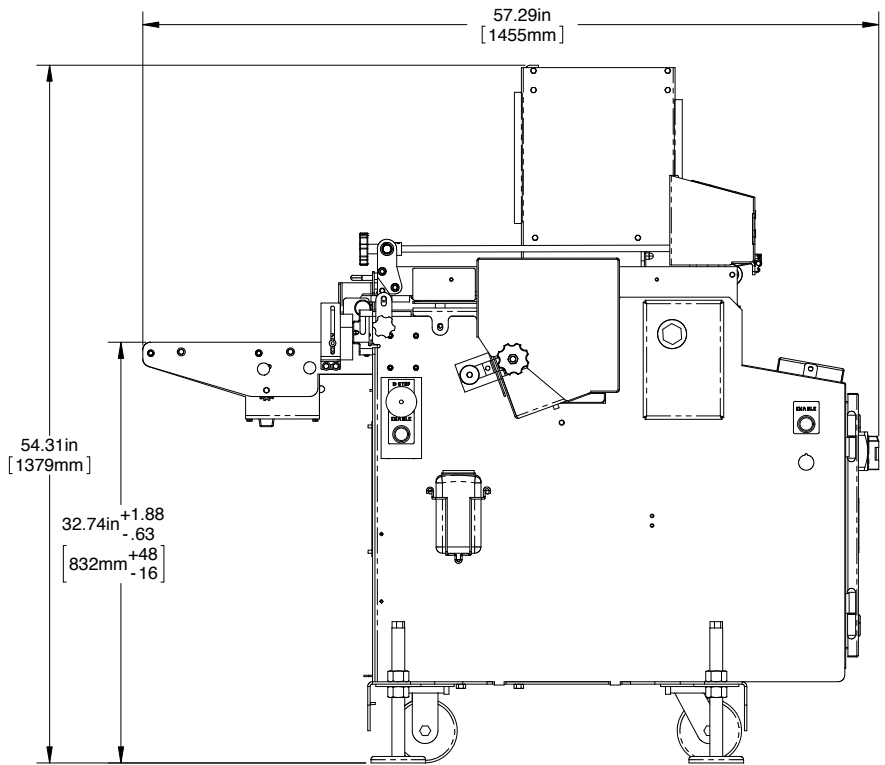

**SIDE VIEW**

03.10

## Features

- 60 strokes per minute per lane
- Bulk slice, stack and shingle modes
- Slice counter for grouping slices
- Shuttle conveyor for product stacking or shingling
- Up to 3" (76mm) stack height
- Variable speed carryout conveyor
- 7" x 13" (178 mm x 330 mm) slicing zone
- 713 product holders adaptable to the 713-SS
- 713 blade guides interchangeable with the 713-SS
- Variable slice thickness of .02" to .5" (.5 mm to 12.7 mm); thicker cuts possible with modifications
- Electrical 200-240 VAC, 50/60Hz, 1 phase
- Utilizes AccuBand cutting system
- Gravity feed product method

### Corporate Office

1160 Gahanna Parkway  
Columbus, OH 43230  
United States of America  
Tel.: 614-868-8414  
Fax: 614-863-1647

E-mail: sales@grotecompany.com



*Precision slicing & application systems*

[www.grotecompany.com](http://www.grotecompany.com)

### European Sales & Service

Wrexham Technology Park  
Wrexham, North Wales LL137YP  
United Kingdom  
Tel.: 44 (0) 1978-362243  
Fax: 44 (0) 1978-362255

E-mail: sales@intl.grotecompany.com