

ELECTRIC PEPPAMATIC (e-Pepp)

Grote's electric Peppamatic is ideal for frozen pizza production lines. It slices and applies pepperoni directly onto pizza crusts in a predetermined pattern.

The electric Peppamatic applies pepperoni to various sizes and shapes of pizza crusts, as well as to French bread crusts. Pepperoni placement patterns are custom designed to suit your requirements.

Product output may be adjusted to a maximum of 45 twelve inch pizzas per minute, per lane, on multiple head units (multi-lane and tandem configurations also available for higher production capacities). Pepperoni sticks may be continuously loaded into the product holders while the machine is in operation.

Operation is simple. Most functions of the electric Peppamatic can be controlled with the user-friendly touch screen. Functions such as stroke speed and blade start/stop may be adjusted in an instant with the touch of a finger.

Grote's electric Peppamatic has unmatched slice quality and targeting accuracy. It will be an invaluable addition to your pizza production line.



Count on Grote for *all* your slicing needs!

Model 1515E



Slices and applies pepperoni directly onto pizza crusts in a pre-determined pattern.

AccuBand

The electric Peppamatic utilizes Grote's patented AccuBand® cutting system for optimal slice quality and product yield. AccuBand cuts with a 1/2" wide razor-sharp band blade running continuously between two pulleys. The blade cleanly and consistently cuts through the entire product log, including butt ends, to produce the highest yield of usable slices. These disposable blades eliminate the need for resharpening and simplify the cleanup process.

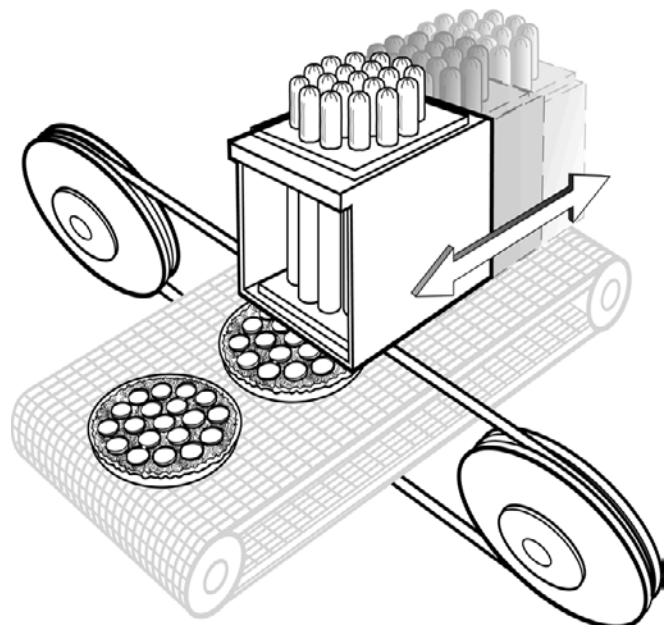

Dimensional Drawings

**Model
1515E**

**PLAN
VIEW**

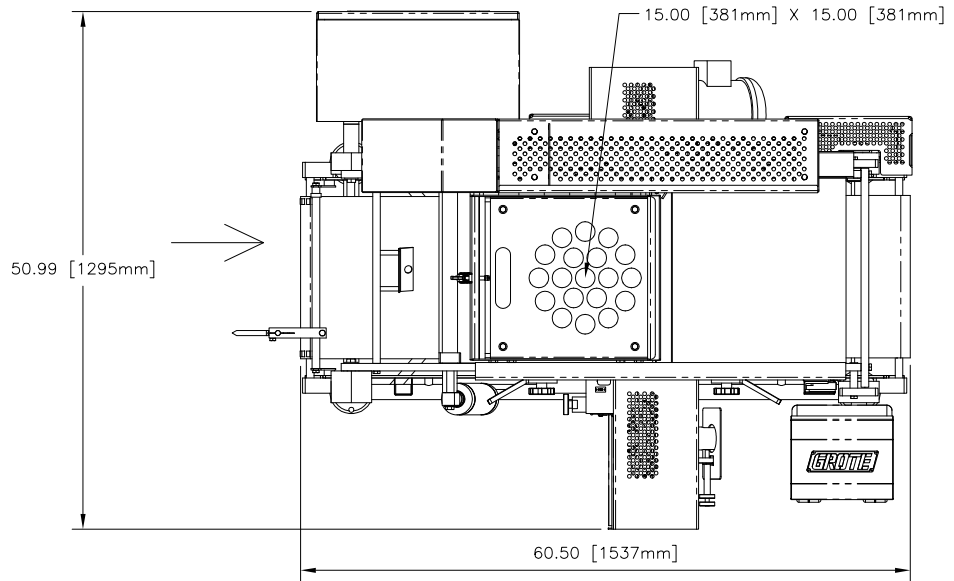

**ELEVATION
VIEW**

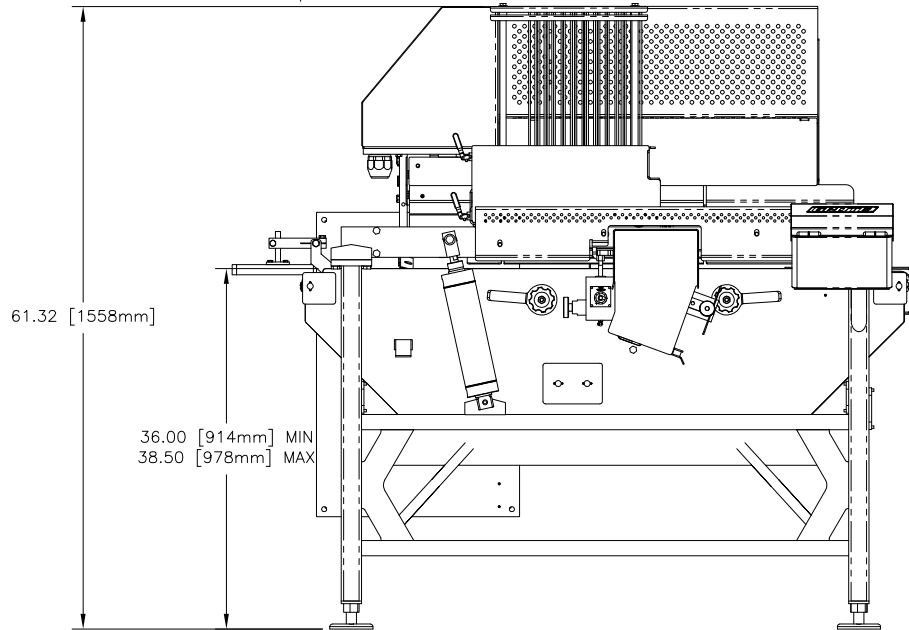

08.10

Features

- Maximum rate of 45 twelve inch pizzas per minute, per lane, on single head units (multi-lane and tandem configurations also available for higher production capacities)
- All electric, servo driven timing belt for cluster drive
- Fully programmable stroke length
- Pizza crust thickness range of .6" to 2.5"
- Line height: minimum 36" and maximum of 40"
- Fine adjust slice thickness control with dial indicator
- .03" to .14" slice thickness range
- Single lane unit has 16" wide x 60.50" long thru conveyor
- Right-hand or left-hand frame
- Standard wire belt conveyor (other belts available)
- Electrical: 200-575 VAC, 3 Phase, 50/60 Hz
- Utilizes AccuBand® cutting system
- Continuous gravity feed product loading during operation
- Open frame, stainless steel construction for greatly enhanced sanitation and maintenance
- Dimensionally interchangeable (footprint) with many older hydraulic Peppamatic models
- 15.00" wide x 15.00" long cut zone

Corporate Office

1160 Gahanna Parkway
Columbus, OH 43230
United States of America
Tel.: 614-868-8414
Fax: 614-863-1647

E-mail: sales@grotecompany.com



Precision slicing & application systems

www.grotecompany.com

European Sales & Service

Wrexham Technology Park
Wrexham, LL137YP
United Kingdom
Tel.: 44 (0) 1978-362243
Fax: 44 (0) 1978-362255

E-mail: sales@intl.grotecompany.com