

713-SS MULTI-SLICER

Grote's 713 Multi-Slicer has been a staple in the food service industry for over 20 years. The Grote 713-SS combines the same great versatility found in the 713 Multi-Slicer with several significant enhancements over previous models, including off-the-shelf electrical controls and an improved sanitary design. The new sanitary design includes sloped surfaces, substantially stainless steel construction, and a sealed cabinet for superior washdown protection of the clutch unit.

The 713-SS can perform a variety of slicing applications, including bulk slicing, stacking, and shingling into portions. In addition, its linear stroke action makes the 713-SS perfect for specialty slicing applications, such as bias cutting, and its 7" x 13" (177 mm x 330 mm) cut zone is ideal for slicing large whole muscle meat products. Boneless/non-frozen meats, cheeses, vegetables, fruits, and bread products are all precisely sliced at a rate of 60 strokes per minute per lane. Operation and sanitation are simple. The user friendly keypad utilizes easily identifiable symbols to allow for quick and easy selection of slicer functions. Product may be continuously loaded into the product holders and slice thickness can be easily adjusted while the machine is in operation.



Model 713-SS

Bulk slices, stacks, and shingles into portions at a rate of 60 strokes per minute, per lane.



AccuBand®

The 713-SS Multi-Slicer utilizes Grote's patented AccuBand® cutting system for optimal slice quality and product yield. AccuBand® cuts with a .5" (12.7 mm) wide razor-sharp band blade running continuously between two pulleys. The blade cleanly and consistently cuts through the entire product log, including butt ends, to produce the highest yield of usable slices. These disposable blades eliminate resharpening and simplify the cleanup process.

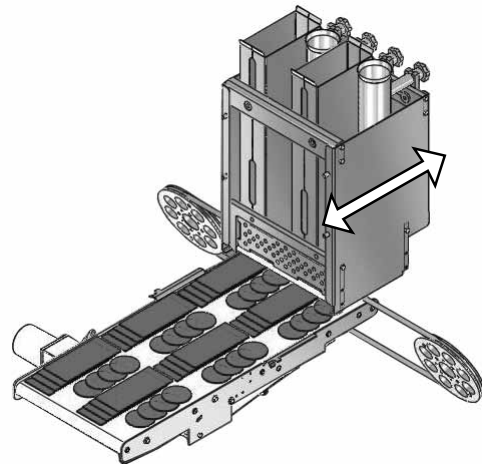

See equipment demonstration videos at www.grotecompany.com/slicers



Dimensional Drawings

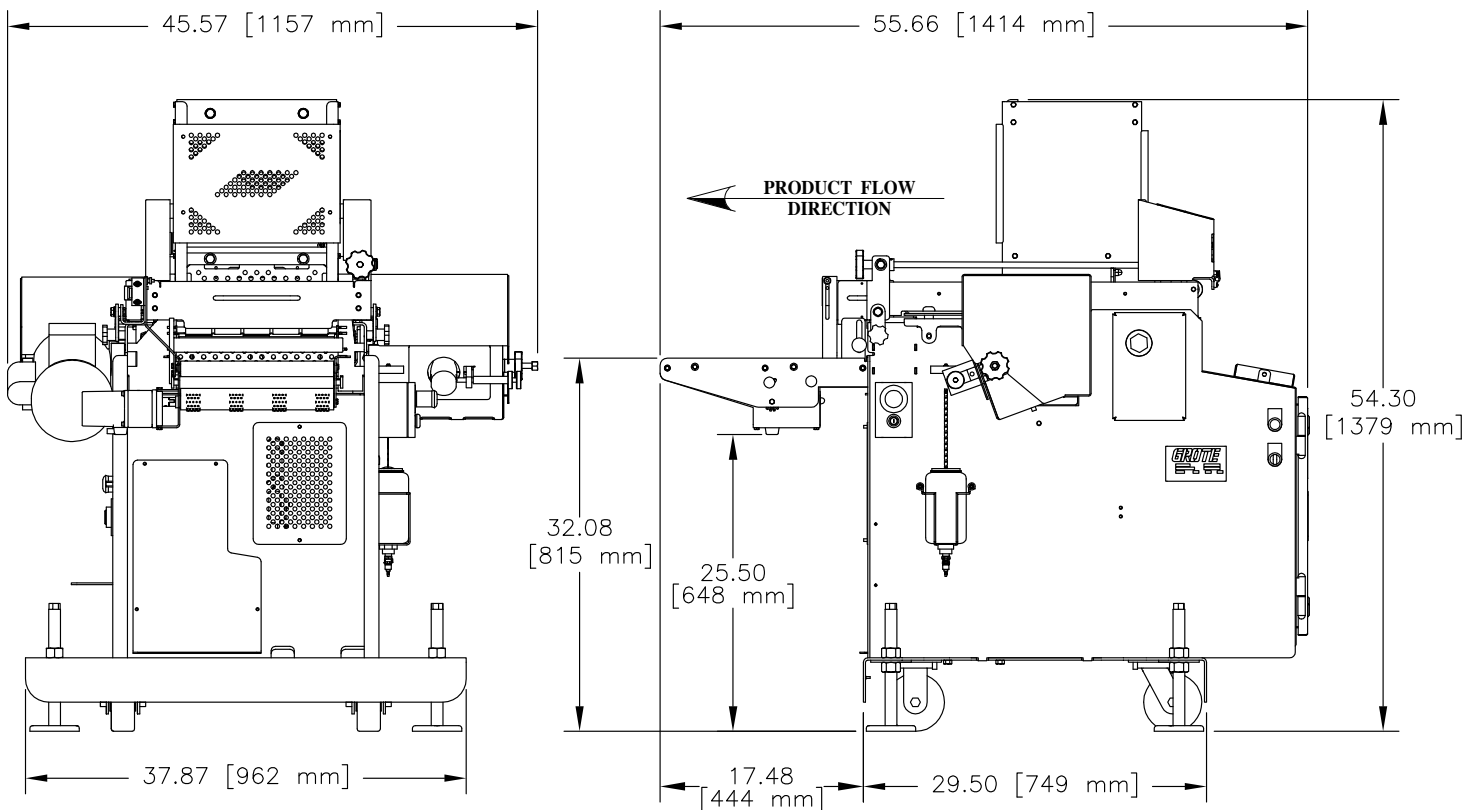

ALL DIMENSIONS ARE APPROXIMATE
PRIMARY DIMENSIONS IN INCHES

Features

- 60 strokes per minute per lane
- Bulk slice, stack and shingle modes
- Slice counter for grouping slices
- Shuttle conveyor for product stacking or shingling
- Up to 2.25" (57 mm) stack height
- Variable speed carryout conveyor
- 7" x 13" (178 mm x 330 mm) slicing zone
- 713 product holders adaptable to the 713-SS
- 713 blade guides interchangeable with the 713-SS
- Variable slice thickness of .02" to .5" (.5 mm to 12.7 mm); thicker cuts possible with modifications
- Electrical 200-240 VAC/ 50/60Hz/ 1 phase
- Utilizes AccuBand® cutting system
- Gravity feed product method

12.11

Corporate Office

1160 Gahanna Parkway
Columbus, OH 43230, USA
US Tel: 614-868-8414
US Toll Free: 888-534-7683
US Fax: 614-863-1647
e-mail: sales@grotecompany.com



Precision slicing & application systems

www.grotecompany.com

European Sales & Service

Wrexham Technology Park
Wrexham, LL137YP, UK
Tel: +44 (0) 1978-362243
Fax: +44 (0) 1978-362255
e-mail: sales@intl.grotecompany.com