

WATERFALL TOPPING APPLICATOR (AP SERIES)

Grote's AP Series Waterfall Topping Applicator is ideal for evenly applying a wide variety of toppings onto pizza production lines, including shredded cheese, dry ingredients, and individually quick frozen (IQF) meats or vegetables. With its cantilevered frame and open channel welded construction, the AP Series applicator offers superior sanitary design and exceptional performance.

Built for the most demanding food processing environments, the AP Series applicator is manufactured of rugged, corrosion resistant stainless steel and utilizes FDA compatible thermoplastics in all food and splash zones. Available in three standard widths 20" (508 mm), 30" (762 mm) and 40" (1014 mm), the hopper and pass-through conveyor belts are easily removable in less than 5 minutes for daily cleaning, and both conveyors include stainless steel bearings, motors and gearboxes as standard features.

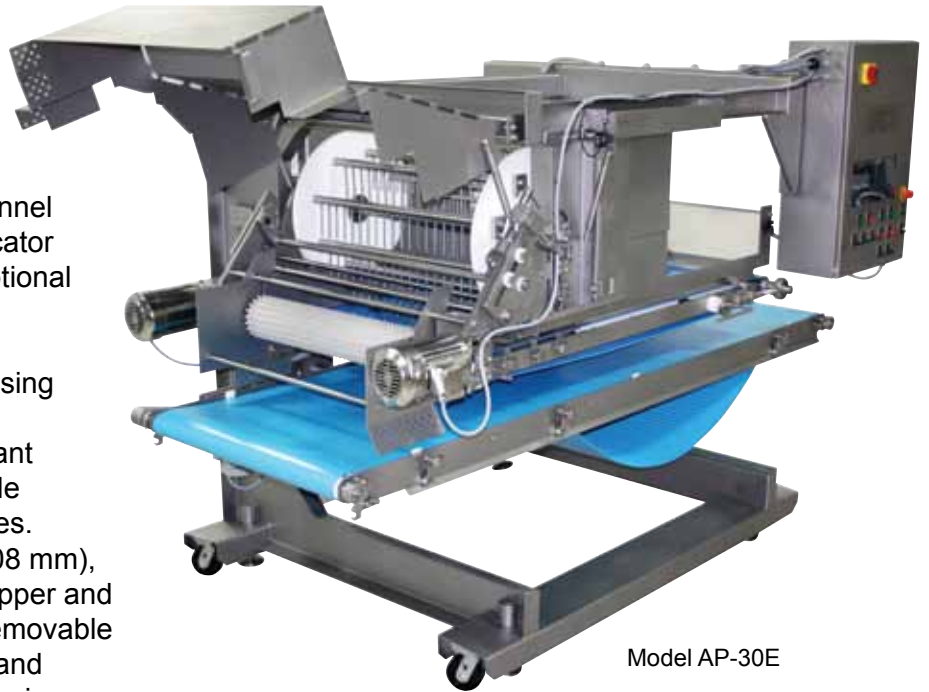

Model AP-30E

Ideal for evenly applying a wide variety of toppings onto pizza production lines, including shredded cheese, dry ingredients, and individually quick frozen (IQF) meats or vegetables.



Grote's AP Series Waterfall Topping Applicator offers several innovative design features which optimize both efficiency and performance. Grote's unique hopper rake system utilizes round tines to provide for better product distribution and less product damage over a wide range of toppings. In addition, the flinger wheel offers compound adjustability for superior trajectory control of toppings over the full range of IQF products.

For maximum efficiency, Grote offers an optional 3 belt return conveyor system to recapture, recirculate and reload excess topping ingredients into the hopper. Other options include an adjustable height rake assembly with indicator scale and single point adjustment, and automatic hopper level control. Whether you are depositing onto pizza crusts, French Bread, or bagels, Grote's AP Series Waterfall Topping Applicator offers exceptional performance and superior hygienic design.

Count on Grote for all your slicing needs!



Dimensional Drawings

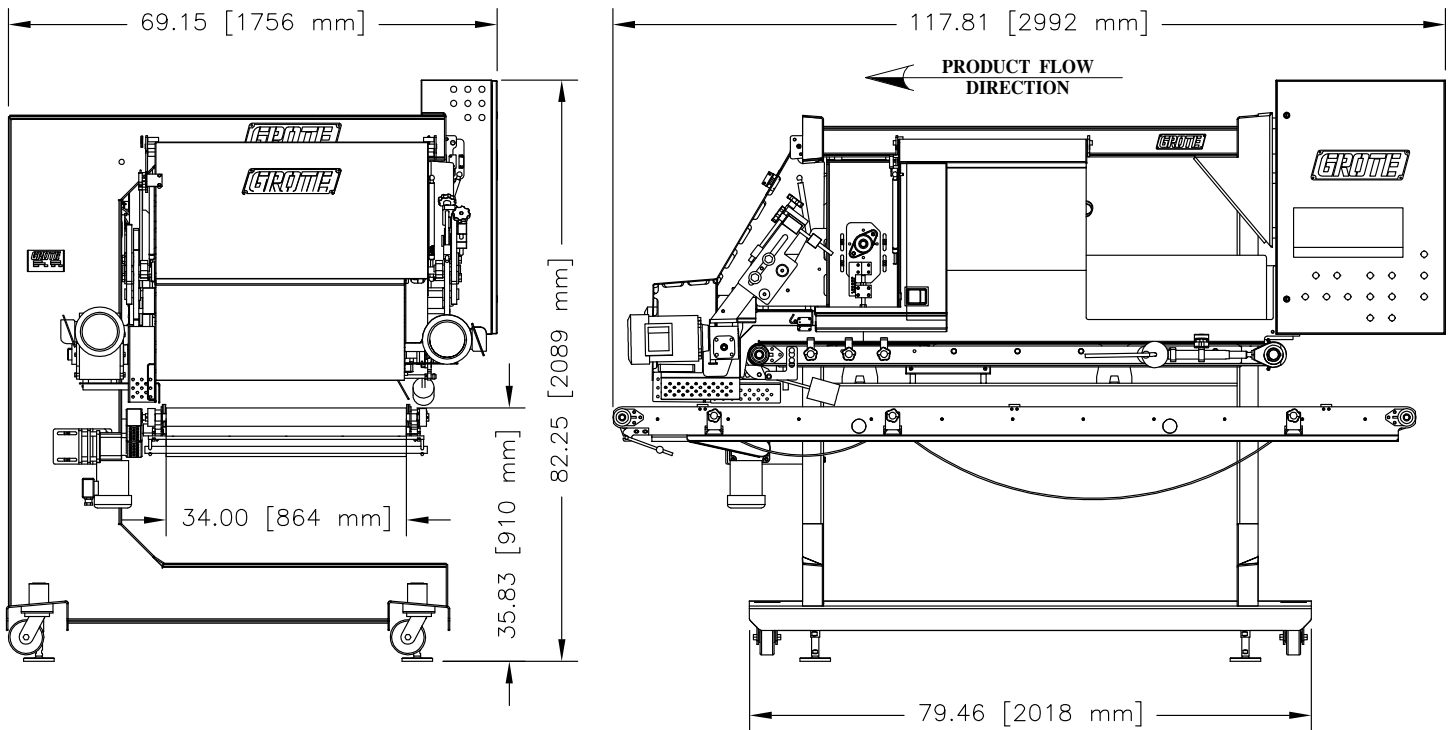

ALL DIMENSIONS ARE APPROXIMATE
PRIMARY DIMENSIONS IN INCHES

Features

Model AP-30E shown

- Minimum line height 35 1/8" (892.71 mm) – nominal maximum 37 3/8" (949.32 mm)
- Electrical: 208/230 VAC/ 3 phase/ 60Hz
- Pneumatic: 60psi
- Washdown - IP 65 electrical rating
- Enhanced safety guarding
- Stainless steel construction
- Food approved polyurethane belting
- Cantilevered design for easy belt changing and cleaning
- Sanitary leveling feet with casters
- Optional – 3 belt return conveyor system
- Optional – adjustable height rake assembly with indicator scale
- Optional – automatic hopper level control

Corporate Office
 1160 Gahanna Parkway
 Columbus, OH 43230, USA
 US Tel: 614-868-8414
 US Toll Free: 888-534-7683
 US Fax: 614-863-1647
 e-mail: sales@grotecompany.com

Precision slicing & application systems
www.grotecompany.com

European Sales & Service
 Wrexham Technology Park
 Wrexham, LL13 7YP, UK
 Tel: +44 (0) 1978-362243
 Fax: +44 (0) 1978-362255
 e-mail: sales@intl.grotecompany.com